

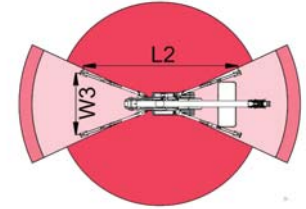

25 m ↑
13 m →
250 Kg 🧑🧑

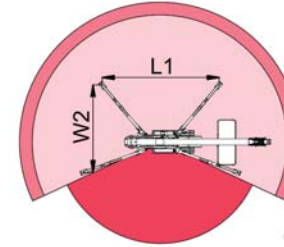
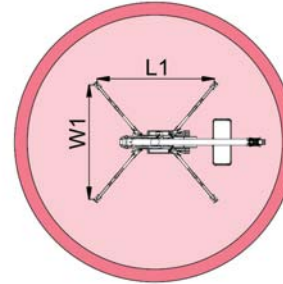
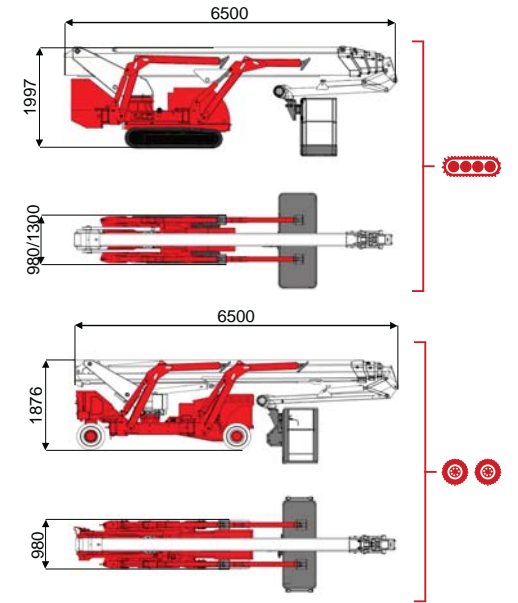
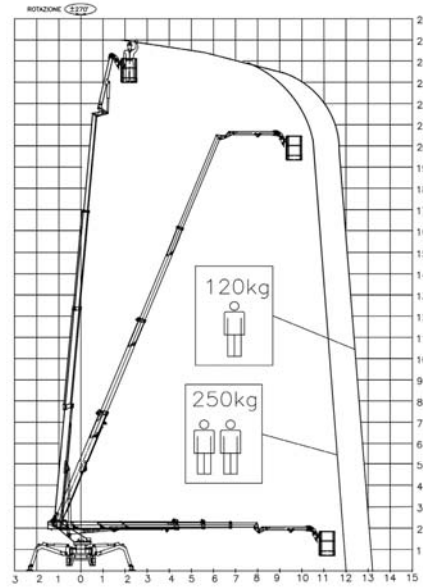

12000 mm	13200 mm	7000 mm	L1	L2	W1	W2	W3
250 kg	120 kg	120/250 kg	4971 mm	6542 mm	4853 mm	3732 mm	2610 mm

BI-ENERGY
Diesel+AC



TSJ 25/C	🔋	25 m	13 m	250 kg	175°	540°	180x70 cm	90°+80°	2,6-4,85 m	30%	40%	1,4 km/h	3950 kg	26 kN	1,78 kN/m ²	3,21 kN/m ²	980/1300 mm	6500 mm	1997 mm
----------	---	------	------	--------	------	------	-----------	---------	------------	-----	-----	----------	---------	-------	------------------------	------------------------	-------------	---------	---------

TSJ 25/R	⊗ ⊗	25 m	13 m	250 kg	175°	540°	180x70 cm	90°+80°	2,6-4,86 m	30%	25%	1,3 km/h	3950 kg	26 kN	1,78 kN/m ²	3,21 kN/m ²	980 mm	6500 mm	1876 mm
----------	-----	------	------	--------	------	------	-----------	---------	------------	-----	-----	----------	---------	-------	------------------------	------------------------	--------	---------	---------

	🔋	🔋⚡	+ Kg	🕒	🕒🔋⚡	📦	
	Battery type	Battery charge	Add. Weight	Autonomy	Charging time	Electropump	
ECO	DC+AC 🔋	48V 320 A/h 5h	230V-48V 45A	450 kg	6-7 h endless	7h	48V 12 kW
ECO	DC+AC ⊗ ⊗	48V 270 A/h 5h	230V-48V 45A	400 kg	6-7 h endless	7h	48V 9 kW
HYBRID	Diesel+DC 🔋 ⊗ ⊗	24V 240 A/h 5h	230V-24V 35A	200 kg	2-3 h endless	7h	24VD 3 kW